

AN - 148  
January 15, 1951

## Efficient Deflection and High-Voltage Circuits for Kinescopes Such As RCA-14EP4 and RCA-17CP4

This Note describes a new, efficient deflection system which provides ample deflection and a 14-kilovolt anode supply for kinescopes such as the RCA-14EP4 and the RCA-17CP4 having horizontal-deflection angles of about 66 degrees. The horizontal-deflection circuit is designed around the new ferrite-core transformer RCA-224T1 and uses a single 1B3-GT high-voltage rectifier, together with a 6BQ6-GT horizontal-output tube, and a 6W4-GT damper diode. A B-supply of only 250 volts is required. With this voltage, the total power consumption of the horizontal-deflection and high-voltage circuit plus that of the vertical-deflection circuit is about 27 watts.

This deflection system contributes to low-cost receiver design because it uses inexpensive tubes and components, and has modest requirements for B voltage and B current. Moreover, it provides good picture linearity and an anode supply voltage which is high (14 kilovolts) and has good regulation. Pulse voltages at the yoke, the 6W4-GT cathode, and the 6BQ6-GT plate are safely within ratings, a fact that contributes to long life and trouble-free operation. Barkhausen oscillations have never been detected; there is little possibility of their occurrence because the plate of the 6BQ6-GT never becomes negative.

### Transformer and Yoke

The RCA-224T1 horizontal-deflection-output and high-voltage transformer is of the autotransformer type with layer-wound coils. The high-permeability ferrite core permits the use of a small coil and contributes to the overall compactness of the unit. This transformer, when used in the recommended circuits, withstands the over-voltage tests of the Underwriters' Laboratories, Inc.

The transformer ratio is designed for deflecting yoke RCA-209D1 which has horizontal-deflecting coils of approximately 14 millihenries. The use of a ferrite core in the yoke permits the attainment of good deflection sensitivity. A 0.25 microfarad capacitor, C<sub>20</sub>, is placed in series with the horizontal-deflecting coils of the yoke to block direct current which would decenter the raster. The use of this value of capacitance also improves the linearity for kinescopes requiring wide-angle scanning on a relatively flat face.



## Linearity Control

Linearity correction for the horizontal scanning circuit is provided by the use of linearity control RCA-209R1. Scanning linearity is also affected by the waveform of the 6BQ6-GT grid voltage (the waveform should not be a perfectly linear sawtooth) and by the current drain from the boosted B supply. The turns ratio of the horizontal-deflection transformer is such that a current of up to 12 milliamperes from the boosted B-supply is obtainable for the vertical-deflection circuit without adverse effects.

## Width Control Methods

In Fig.1 an unbypassed 200-ohm variable resistor,  $R_{17}$ , in series with the B-supply lead to the deflection circuits functions as a width control. This arrangement for controlling picture width is particularly suited to compensate for line-voltage variations. After the proper aspect ratio has been obtained by adjustment of the height control in the vertical-output circuit, picture width may be varied by adjustment of the width control, an adjustment which automatically maintains the proper aspect ratio. In addition, with this type of control the anode voltage for a given beam current is dependent only upon the size to which the picture is adjusted. The power dissipation in this control can be determined from its resistance and rms current. The latter should be measured with a thermal-type instrument to avoid errors due to the fact that the current is non-sinusoidal.

Similar control of picture width may be attained with other methods. For example, a variable resistor may be used to vary the screen voltage of the 6BQ6-GT and thus provide simultaneous variation of picture width and height. Care should be taken, however, that the screen input and screen voltage ratings of the 6BQ6-GT can not be exceeded with any adjustment of this control.

Another method of controlling picture width is to connect a variable inductor across some portion of the RCA-224T1 so that the inductor effectively shunts the horizontal-deflecting coils. This method controls picture width, but has little effect on picture height. A properly designed variable inductor permits width reduction without significant reduction in the voltage of the kinescope anode. The minimum inductance of the control is chosen to effect the required maximum reduction in width. The maximum inductance must be as large as practicable to minimize the loss of width at the maximum width adjustment.

This method of control imposes two limitations on the width adjustment. One limitation is the heating of the autotransformer windings caused by the current drawn by the width-control inductor. The second limitation results from the increase in plate dissipation in the horizontal-output tube due to the reduction of the effective plate-load impedance as the width is reduced. When a width-control inductor is used, it should be connected to terminals 5 and 7 of the RCA-224T1 transformer. This connection minimizes transformer heating and permits the use of a coil having a relatively low inductance. A control with a minimum inductance of as low as 1.5 millihenries may be used without causing excessive temperature rise in the autotransformer.

## Lead Dress

The primary consideration in lead dress is to minimize stray capacitance. Excessive capacitance between any point on the transformer and ground appreci-

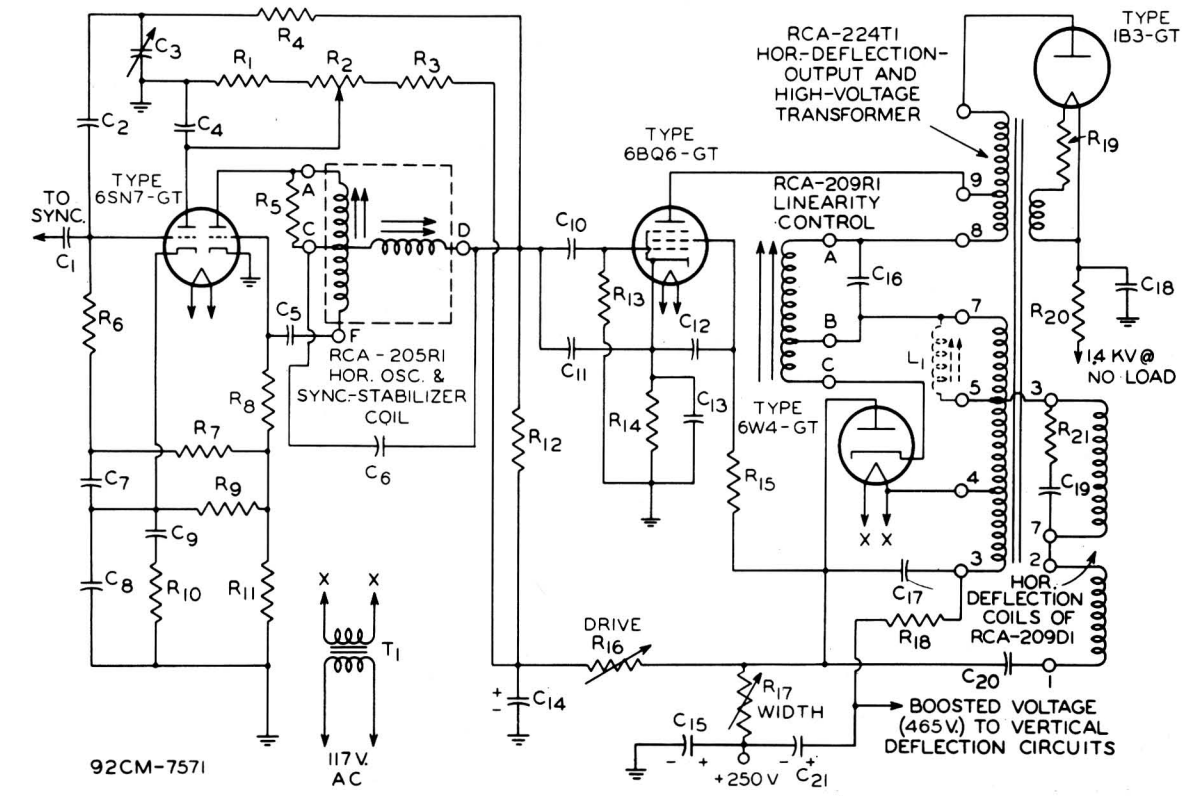

- |  |  |  |
|--|--|--|
| C1 C2: 82 $\mu\text{f}$ , 500 v., mica                       | C16: 0.04 $\mu\text{f}$ , 400 v.                       | R12: 68000 ohms, 1 watt  |
| C3: Locking range control, 8-70 $\mu\text{f}$ , mica trimmer | C17: 0.03 $\mu\text{f}$ , 600 v.                       | R13: 0.47 megohm, 0.5 watt   |
| C4: 0.05 $\mu\text{f}$ , 400 v.                              | C18: 500 $\mu\text{f}$ , 20 kv.                        | R14: 100 ohms, 2 watts   |
| C5: 330 $\mu\text{f}$ , 500 v., mica                         | C19: 56 $\mu\text{f}$ $\pm$ 5%, 800 v.                 | R15: 6800 ohms approx., 2 watts                                    |
| C6: 0.01 $\mu\text{f}$ , 600 v., oil-filled                  | C20: 0.25 $\mu\text{f}$ , 400 v.                       | R16: Drive control, 25000-ohm potentiometer, 2 watts               |
| C7: 0.05 $\mu\text{f}$ , 400 v.                              | C21: 10 $\mu\text{f}$ , 250 v., type DEE or equivalent | R17: Width control, 200-ohm potentiometer, 5 watts                 |
| C8: 0.02 $\mu\text{f}$ , 400 v.                              | R1: 0.12 megohm, 1 watt                                | R18: 1000 ohms, 1 watt   |
| C9: 0.5 $\mu\text{f}$ , 400 v.                               | R2: Hold control, 50000-ohm potentiometer, 2 watts     | R19: 3.3 ohms, 0.5 watt  |
| C10: 0.003 $\mu\text{f}$ , 600 v.                            | R3: 47000 ohms, 1 watt                                 | R20: 50000 ohms min., 1 watt                                       |
| C11: 820 $\mu\text{f}$ , 500 v., mica                        | R4 R8: 0.15 megohm, 1 watt                             | R21: 1000 ohms, 0.5 watt   |
| C12: 0.1 $\mu\text{f}$ , 400 v.                              | R5: 8200 ohms, 0.5 watt                                | T1: Heater transformer insulated for 1.5 kv peak                   |
| C13: 0.25 $\mu\text{f}$ , 200 v.                             | R6: 0.33 megohm, 0.5 watt                              | L1: Alternate width control, min. inductance, 1.5 mh, ferrite core |
| C14: 10 $\mu\text{f}$ , 250 v., electrolytic                 | R7: 0.82 megohm, 0.5 watt                              |  |
| C15: 20 $\mu\text{f}$ , 250 v., electrolytic                 | R9: 82000 ohms, 1 watt                                 |  |
|  | R10: 3900 ohms, 0.5 watt                               |  |
|  | R11: 0.33 megohm, 1 watt                               |  |

NOTE: Terminals A, B, and C of the RCA-209R1 Linearity control can be identified by resistance measurements. The resistance between terminals A and B is approximately 4 ohms and the resistance between terminals B and C is approximately 1.5 ohms.

Fig. 1 - Horizontal-Deflection and High-Voltage Circuit.

ably increases the retrace time and reduces the high voltage obtained. The stray capacitance at the plate connection to the 1B3-GT high-voltage rectifier is the most critical. Because most of the circuit capacitance introduced at that point is stray capacitance rather than the plate-to-filament capacitance of the tube, it is necessary to keep the plate lead as short as possible. It is also desirable to position the 1B3-GT so that the capacitance between its plate and the chassis is minimized.

The leads of the 224T1 transformer should also be dressed so as to minimize electrostatic coupling with the lead to the 6BQ6-GT grid. If coupling of the retrace pulse into the 6BQ6-GT grid circuit is not minimized, plate





conduction may occur during retrace. Because the plate voltage during retrace is high, even a small amount of plate current during retrace would cause appreciable increase in plate dissipation and a substantial reduction of circuit efficiency.

Another consideration in lead dress is the possibility of coupling between the horizontal-deflection-and-high-voltage circuit and other parts of the receiver. Coupling of this circuit with the video amplifier or kinescope grid lead may cause modulation of the beam and resultant light-and-dark bands in the raster. These bands have an appearance similar to bands caused by "ringing" in the deflection circuit.

### **6W4-GT Heater Transformer**

If one side of the 6W4-GT heater in this circuit were grounded, the heater-cathode ratings of the tube would be exceeded. For example, at a line voltage of 117 volts, the 6W4-GT cathode reaches a peak voltage of 2700 volts positive to ground and an average voltage of 475 volts positive to ground. Thus, if the heater is grounded, the dc heater-cathode voltage exceeds the rating of 450 volts, heater negative, and the heater-cathode pulse voltage exceeds the rating of 2100 volts, heater negative. The dc voltage between heater and cathode can be removed by connecting the heater to any terminal of the horizontal-deflection transformer. When this connection is made to terminal 4, the pulse voltage between heater and cathode is reduced to 1600 volts. The capacitance between the heater winding of the transformer and ground has an effective value at the yoke connection, terminal 5, of only 0.1 of its actual value. Consequently, this capacitance has only a relatively minor effect on horizontal-retrace time. Although it is desirable that the capacitance of the heater-transformer winding for the 6W4-GT be small, values up to approximately 250 micromicrofarads are tolerable, and the variations in capacitance which normally occur in production have no appreciable effect upon the scanning circuit.

In some circuit designs it may be possible to connect the 6W4-GT heater to terminal 3 of the RCA-224T1 transformer. The chief advantage of this arrangement is that it eliminates the possibility of interference with broadcast receivers caused by harmonics of the scanning-frequency pulses coupled into the power line through the 6W4-GT heater transformer. It should be noted that under the 14-kilovolt operating conditions given in Table I the heater-cathode pulse voltage with such a connection is about 2200 volts, which value exceeds the tube rating of the 2100 volts. In this case, therefore, this connection is not recommended.

Because the peak voltage from terminal 4 of the horizontal-deflection transformer to ground is only about 1100 volts, the insulation requirements for the 6W4-GT heater-transformer winding present no difficulties.

### **Drive Requirements**

The circuit diagram in Fig. 1 illustrates the use of a blocking-oscillator discharge circuit as a driver for the 6BQ6-GT, but any of the familiar sawtooth-generating devices may be used provided it supplies a driving voltage of the proper amplitude and waveform to the grid of the 6BQ6-GT.

The designer should provide for enough adjustment of the amplitude of the driving voltage so that the condition of excess drive may be attained.

Excess drive is characterized by the appearance of a bright vertical line near the center of the raster. The proper driving voltage is slightly less than that which just causes the bright line to appear.

For optimum circuit efficiency and picture linearity, the driving sawtooth should be somewhat nonlinear. It is possible to obtain a good sawtooth waveform by utilizing the normal exponential curvature of the sawtooth voltage developed by conventional drive circuits in which a capacitor is charged through a resistance. In practice, the desired waveform may be obtained by using the proper value of B supply voltage in the charging circuit. The proper value of B supply voltage must be determined experimentally, be-

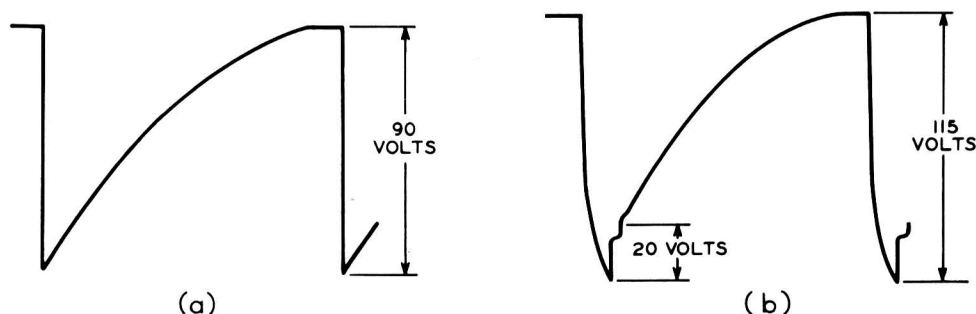

*Fig. 2 - Typical Driving-Voltage Waveforms Applied to Grid of 6BQ6-GT.  
 (a) Waveform from Blocking Oscillator (b) Waveform from Multivibrator.*

cause different circuits utilize different portions of the exponential charging curve in the formation of the sawtooth. With the circuit shown, it is possible to obtain a driving voltage of good waveform and adequate amplitude with a supply voltage of less than 250 volts.

Although it is easier to obtain a driving voltage of adequate amplitude if the boosted B supply from the deflection circuit is utilized, two disadvantages result from the use of this supply. First, more power input to the deflection circuit is required because the drain from the boosted B supply is increased. Second, the regulation of the high-voltage supply is impaired slightly. The boosted B voltage decreases appreciably at high kinescope beam currents, with the result that the amplitude of drive is decreased at high anode currents. The anode voltage is, therefore, further decreased.

Another method of obtaining the optimum driving waveform is to use degeneration in the cathode circuit of the 6BQ6-GT. For the application of this method, it is necessary to start with a sawtooth voltage of reasonably good linearity. This requirement usually makes it mandatory that the sawtooth generator use the boosted B voltage supply. Also, the discharge capacitor,  $C_{11}$ , should be returned to ground rather than to the 6BQ6-GT cathode as shown in Fig. 1. The waveform of the driving voltage between grid and cathode of the 6BQ6-GT is then altered by the use of a cathode bypass capacitor which presents an appreciable impedance at the scanning frequency. The value of the cathode bypass capacitor should be varied to give the best circuit efficiency. The attainment of best efficiency is an indication that the proper waveform has been attained. Because degeneration is introduced in the cathode circuit, the amplitude of driving voltage must be adjusted for each trial value of cathode bypass capacitor. With a value of cathode



resistor that is practical in this circuit, the value of the bypass capacitor will be approximately 0.25 microfarads.

A further requirement of the driving voltage is that it cut off the 6BQ6-GT rapidly at the end of each scanning cycle. Conventional blocking-oscillator discharge circuits complete the cutoff within a time equal to three per cent of the scanning period, a speed of cutoff which has proved to be adequate. If multivibrator or discharge-tube driving circuits are employed, it is necessary to use series-resistance peaking to increase the rapidity of cutoff.

Fig.2a is a tracing of the 6BQ6-GT grid-to-cathode waveform obtained with the circuit of Fig.1. When a horizontal oscillator of the modified Potter-oscillator type is used, equivalent performance is obtained with a driving voltage having a waveshape and amplitude similar to that shown in Fig.2b.

### 1B3-GT Filament Voltage

The filament of the 1B3-GT high-voltage rectifier is energized by a winding on the horizontal-deflection transformer. The voltage obtained from this winding depends upon the deflection energy delivered by the circuit. Because the performance requirements of individual circuit designs will vary, the designer should make certain that the filament of the 1B3-GT is being operated within ratings.

The filament voltage of the 1B3-GT may be measured with thermal-type instruments, or by a comparison of the brightness temperature of the 1B3-GT filament under operation with that of a 1B3-GT operated from a dc supply which can be accurately adjusted. The filament voltage-dropping resistor, if required, should be selected so that the filament voltage is approximately 1.25 volts with normal picture brightness and normal line voltage. In addition, the filament voltage should not exceed 1.5 volts under conditions of high line voltage and zero kinescope-anode current. The latter requirement may necessitate some adjustment in the value of the resistor.

### 6BQ6-GT Cathode Resistor

It is recommended that the deflection tubes and receiver power supply be protected in the event of failure of the horizontal-oscillator circuit. The plate dissipation of the 6BQ6-GT increases when the drive voltage is removed, because the power input to the horizontal-deflection circuit increases and also because practically all the input is then dissipated in the tube. The tube currents, however, generally do not increase sufficiently to make the use of a fuse practical for the protection of the 6BQ6-GT. The recommended method of protection, therefore, is to use a cathode resistance large enough to limit the current and dissipation in the 6BQ6-GT to a safe value when the grid-resistor bias is removed. The 6BQ6-GT can operate with a plate dissipation as large as three times the rated value of 10 watts for as long as five minutes with little danger of serious damage to the tube. When the proper value of cathode resistance is used, the power input to the deflection circuit does not change much when the drive is removed. A cathode resistor of approximately 100 ohms is required in the circuit of Fig.1.

### Vertical Deflection

One RCA-6S4 is used in the vertical-deflection circuit. Because of the high B voltage available from the boosted B supply, a large step-down ratio



is desirable in the vertical-output transformer to minimize current drain. A vertical-output transformer having a turns ratio of 18 to 1 provides ample vertical deflection with approximately 10 milliamperes of plate current. If the current drain on the boosted B supply is not kept below 12 milliamperes, the high voltage and the deflection width will be reduced.

Any of the conventional types of oscillators for vertical-deflection circuits may be used to drive the 6S4 if care is taken in the circuit design. Although there is danger of exceeding the peak plate-voltage rating (2000 volts) of the 6S4, the peak voltage may be kept well within the rating if the waveform of the driving voltage applied to the 6S4's is proper.

Two vertical-deflection circuits using different oscillators are shown in Figs.3 and 4. In order to minimize peak voltages in the vertical output circuit, it is necessary to make the retrace time as long as practicable and to accomplish the retrace with a nearly constant rate of change of current in the yoke. For the circuits of Figs.3 and 4, vertical retrace is completed in approximately three per cent of the field period. This duration of retrace is suitable for use with any standard duration of vertical blanking, which may be from five to eight per cent of the field period. Although peaking amplitude can be varied to adjust the retrace time, excessive peaking causes overshoots and ringing at the end of retrace, and insufficient peaking causes folding at the top of the raster. On the other hand, when the duration of the peaking pulse is varied to adjust retrace time, reasonably linear retrace can be maintained. In most of the designs for blocking oscillators in vertical-deflection circuits, the peaking pulse is too brief and has to be increased in duration.

The linearity of retrace is influenced not only by the amplitude and duration of peaking, but also by the waveshape of the peaking pulse. Most blocking oscillators tend to produce a very rapid current change at the beginning of retrace and a large voltage peak results. Resistor  $R_4$  (82000 ohms) in Fig.4 is used to correct this effect.

### Typical Operation

Table I gives typical operating conditions for the circuits of Figs.1, 3, and 4, with an average 6BQ6-GT tube, with maximum width control adjustment, and with a line voltage of 117 volts. The circuits in which these measurements were made had wiring capacitance comparable to that encountered in a commercial design. The capacitance of the 6W4-GT heater transformer was 220 micromicrofarads.

Table I. Typical Operating Conditions\* for Circuits of Figs.1, 3, and 4

B Voltage. . . . .	250 v	Grid-No.1 Voltage (cathode bias) . . . . .	-25 v
Anode Voltage:		Peak Plate Voltage:	
At no load . . . . .	14 KV	Fig.3 Circuit. . . . .	1500 v
At 140 $\mu$ a beam current . . . . .	12.9 KV	Fig.4 Circuit. . . . .	1800 v
Boosted Voltage. . . . .	475 v		
Boost Current. . . . .	10 ma	<b>6W4-GT</b>	
<b>1B3-GT</b>		Plate Current. . . . .	93 ma
Peak Inverse Plate Voltage . . . . .	16.9 KV	Peak Inverse Plate Voltage . . . . .	2450 v
<b>6BQ6-GT</b>		Heater-Cathode Pulse Voltage . . . . .	1600 v
Plate Current. . . . .	83 ma		
Grid-No.2 Current. . . . .	12.7 ma		
Grid-No.2 Voltage. . . . .	152 v		
Grid-No.2 Input. . . . .	1.9 W		
Grid-No.1 Voltage $\Delta$ . . . . .	-29 v		
<b>6S4</b>			
Plate current. . . . .	10 ma		
Plate Voltage. . . . .	440 v		

\* With a line voltage of 117 volts and picture width adjustment at maximum setting. All values are for zero kinescope anode current unless otherwise noted.

$\Delta$  Composed of 10 volts cathode bias and 19 volts grid-resistor bias.

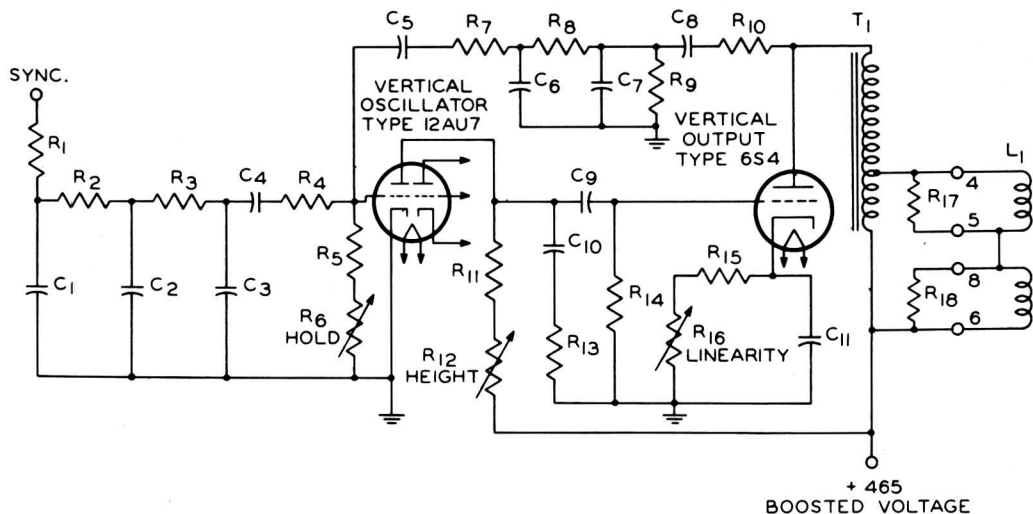

- |   |   |  |
|---|---|--|
| C1 C4 C5: 0.002 $\mu$ f, 400 v.         | R4 R7 R8 R10: 82000 ohms, 0.5 watt        | R15: 470 ohms, 0.5 watt  |
| C2 C3: 0.005 $\mu$ f, 400 v.            | R5: 470000 ohms, 0.5 watt                 | R16: Variable resistor, 5000 ohms, 2 watts   |
| C6: 0.001 $\mu$ f, 400 v.               | R6: Variable resistor, 1 megohm, 1 watt   | R17 R18: 560 ohms, 0.5 watt  |
| C7: 470 $\mu$ f, 500 v., mica           | R9: 100000 ohms, 0.5 watt                 | T1: Vertical output transformer; turns ratio, primary to secondary—18:1; primary impedance 30000 ohms min. at 30 v, 60 cps, superimposed on 12 ma.dc |
| C8: 0.01 $\mu$ f, 600 v.                | R11: 1 megohm, 0.5 watt                   |  |
| C9: 0.1 $\mu$ f, 600 v.                 | R12: Variable resistor, 2 megohms, 1 watt |  |
| C10: 0.05 $\mu$ f, 600 v.               | R13: 15000 ohms, 0.5 watt                 |  |
| C11: 50 $\mu$ f, 50 volts, electrolytic | R14: 2.2 megohms, 0.5 watt                |  |
| R1: 22000 ohms, 0.5 watt                |   |  |
| R2 R3: 8200 ohms, 0.5 watt              |   |  |

Fig. 3 - Vertical-Output Circuit with Feedback Oscillator.

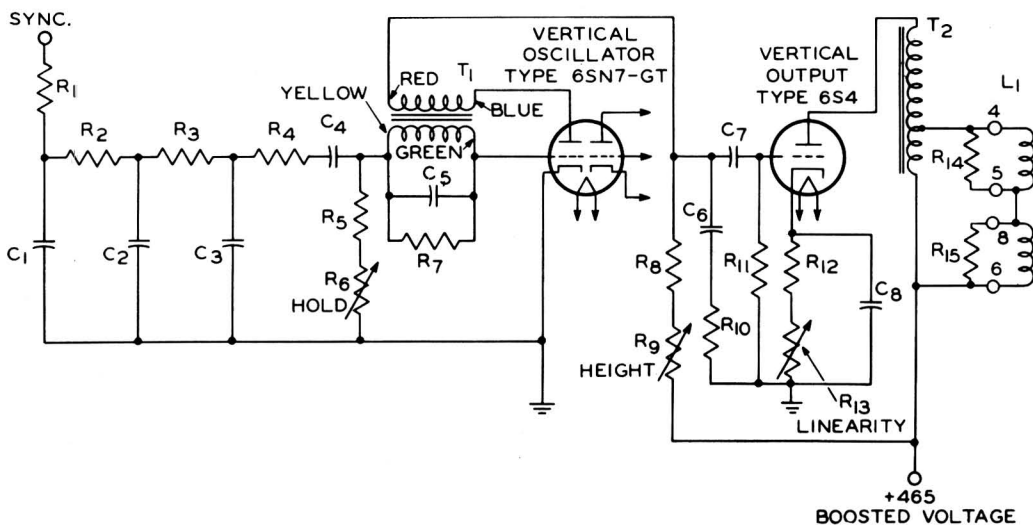

- |                                     |  |   |
|-------------------------------------|--|---|
| C1: 0.002 $\mu$ f, 400 v.           | R2 R3: 8200 ohms, 0.5 watt               | R10: 10000 ohms, 0.5 watt                               |
| C2 C3: 0.005 $\mu$ f, 400 v.        | R4: 82000 ohms, 0.5 watt                 | R11: 2.2 megohms, 0.5 watt                              |
| C4: 0.006 $\mu$ f, 400 v.           | R5: 1.8 megohms, 0.5 watt                | R12: 470 ohms, 0.5 watt                                 |
| C5: 0.0015 $\mu$ f, 400 v.          | R6: Variable resistor, 1 megohm, 1 watt  | R13: 5000 ohms, 2 watts                                 |
| C6: 0.05 $\mu$ f, 600 v.            | R7: 150000 ohms, 0.5 watt                | R14 R15: 560 ohms, 0.5 watt                             |
| C7: 0.1 $\mu$ f, 600 v.             | R8: 270000 ohms, 0.5 watt                | T1: Vertical blocking-oscillator transformer, RCA-208T9 |
| C8: 50 $\mu$ f, 50 v., electrolytic | R9: Variable resistor; 2 megohms, 1 watt | T2: Same as T1 in Fig. 3                                |
| R1: 22000 ohms, 0.5 watt            |  |   |

Fig. 4 - Vertical-Output Circuit with Blocking Oscillator.

devices and arrangements shown or described herein may use patents of RCA or others. Information contained herein is furnished without responsibility by RCA for its use and without prejudice to RCA's patent rights.